



Universal-Wandkonsole

9530-4003-00, 09/2024



Wandmontage/ wall installation

STEP 1



Prüfen Sie vorab, ob Ihre Mauer geeignet ist.
Verwenden Sie geeignetes Montagematerial.
Bei Fragen wenden Sie sich bitte an den Händler,
bei dem Sie die Universal-Wandkonsole gekauft haben.

Check in advance whether your wall is suitable.
Use suitable installation material.
If you have any questions, please contact the dealer
from whom you purchased the universal wall bracket.

STEP 2

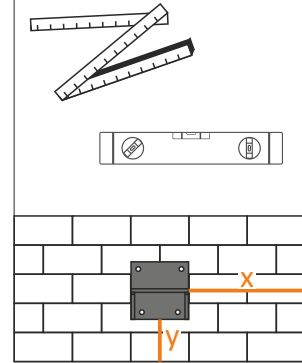

STEP 3

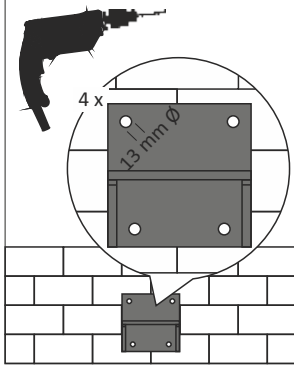

STEP 4

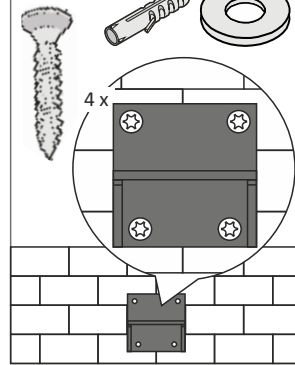

STEP 5

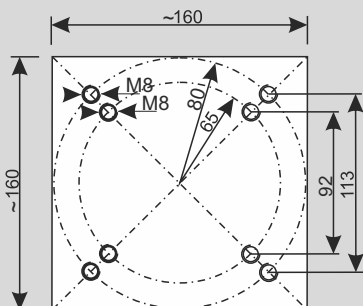
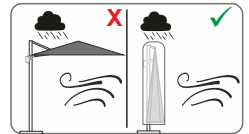
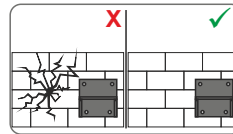
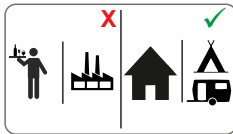
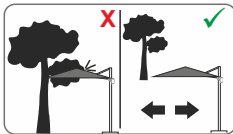
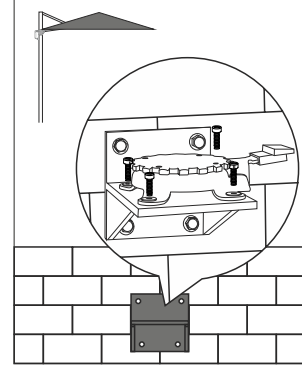

Lochkreis, Angaben in mm/
hole pattern, dimensions in mm

Ⓛ Schirm sicher befestigen, Schirm bei Wind schließen! Ⓜ Fasten parasol securely, close parasol in windy conditions! Ⓝ Fixer solidement le parasol, Fermer le parasol en cas de vent! Ⓞ Ngjitni ombrellën në mënyrë të sigurt dhe mbyllni ombrellën në kushte me erë! Ⓟ Закрепете чадъра здраво, Затворете чадъра при вятър! Ⓠ Slunečnik bezpečně upevněte, Při větru slunečnik zavřete! Ⓡ Fastgør parasollen sikkert, luk parasollen i blæsevej! Ⓢ Kinnitage päikesevari kindlalt, sulgege päikesevari tuulistes tingimustes! Ⓣ ¡Fijar el parasol con seguridad! ¡Cerrar el parasol en caso de viento! Ⓤ Kiinnitä aurinkovarjo tukevasti, sulje aurinkovarjo tuulisissa olosuhteissa! Ⓥ Στερεώσετε καλά την ομπρέλα, Κλείνετε την ομπρέλα όταν φυσάει! Ⓦ Čvrsto pričvrstite suncobran i zatvorite ga u vetrovitim uvjetima! Ⓧ Biztosan rögzítse az ernyőt, Szélben csukja össze az ernyőt! Ⓨ Fissare bene l'ombrellone! Chiudere l'ombrellone in caso di vento! Ⓩ Saugiai pritvirtinkite apsauginį skydelį nuo saulės, esant vėjui tam orui uždarykite apsauginį skydelį nuo saulės! ⓐ Droši nostipriniet saulesargu, vējainā laikā saulesargu aizveriet! ⓑ Paraplu veilig bevestigen, Paraplu bij wind sluiten! ⓓ Fest parasollen godt, og lukk parasollen når det blåser! ⓔ Parasol zamocować bezpiecznie, Parasol podczas wiatru zamknąć! ⓕ Fixar o guarda-sol de forma segura! Fechar o guarda-sol quando levantar vento! ⓖ Umbrella se fixează ferm, Închideți umbrela în cazul în care este vânt! ⓗ Чврсто причврстите сунцобран и затворите сунцобран у ветровитим условима! Ⓢ Fäst parasollet ordentligt, stäng parasollet i blåsiga förhållanden! Ⓣ Varno pritrdite senčnik, v vetrovnihih razmerah ga zaprite! Ⓤ Bezpečně upevnenie slnečníka, Pri veternom počasí uzavrite slnečnik! Ⓥ Şemsiyeyi güvenli bir şekilde sabitleyin, rüzgarlı havalarda kapatın! Ⓦ Надійно закріплюйте парасольку, закривайте парасольку у вітряну погоду!

geeignet für/ suitable for:

Monaco 300 x 300 cm, Bermuda, Rhodos Junior-Serie, Rhodos Grande, Rhodos Twist-Serie, Rhodos, Rhodos Blacklight, Rhodos Rondo, Genua, Mast für Sonnensegel